



INDEPENDENT X-RAY  
QUALITY ASSURANCE



### Mako Specifications

## Unparalleled performance and versatility.

#### New sensor technology

Experience the groundbreaking new sensor technology with best-ever accuracy, unrivalled in the market ( $\pm 1.5\%$  kVp uncertainty across entire measurement range). Place Mako Probes in any orientation in the X-ray beam, for the most efficient measurements of kVp, time, HVL, total filtration, dose and dose rate, while relling in the captivation presentation of waveform data. Offering the broadest application range, including non-invasive mAs (MAS-2) and DAP Chamber applications.

#### Simplified excellence with Plug n Play

Mako adapts to your needs with plug-and-play simplicity, boosting your entire workflow. It's the world's most efficient meter, with the highest practical accuracy and the broadest application range.

#### All-in-one X-ray testing solution

Mako is meticulously designed for modern X-ray equipment, customized to your requirements. Inside our full solution, you'll find the Mako meter, Mako display device, Ocean Next software, and our full probe line-up. Mako is also your exclusive comprehensive solution for non-invasive mAs (MAS-2) and DAP chamber applications.

Mako is future-proof. With its multi-modal design and continuous innovation, it grows with new functions, additional probes, and an ever-broader application range.



Mako Base Unit with Ion Chamber Module docked, and CT Ion Chamber attached.

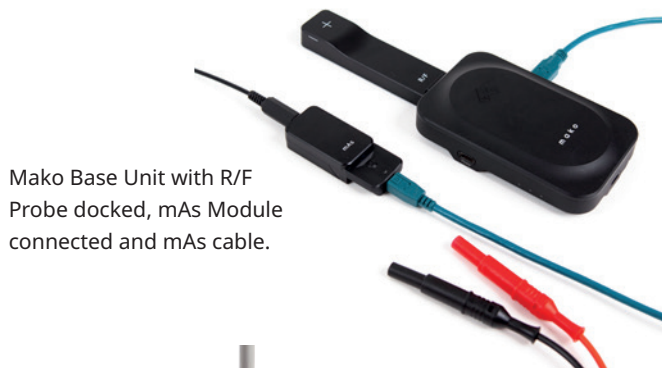

Mako Base Unit with R/F Probe docked, mAs Module connected and mAs cable.



RTI Group Headquarters  
Flöjelbergsgatan 8C  
SE-431 37 Mölndal, SWEDEN

Phone: +46 (0) 31 746 36 00  
sales@rtigroup.com  
www.rtigroup.com

RTI Group North America  
33 Jacksonville Road, Bldg. 1  
Towaco, NJ 07082, USA

Phone: +1 800-222-7537  
sales.us@rtigroup.com  
www.rtigroup.com

### Mako System General Specifications

Live Measurement Display	Mako display device (incl. tablet, laptop, PC)
Software	Ocean Next™
Operating System	Windows 10, 11
Simultaneous Dose Measure	Yes
Bluetooth Range	100 m (free-in-air)
Exposures needed	One
Warranty	2-year
Extended Warranty	10-year
Calibration Cycle	2-year
Standard	According to IEC 61674 and IEC 61676
Directives:	According to 2014/30/EU EMC, 2014/35/EU LVD and 2015/863/ EU RoHS

\*Specifications in this document may be changed without notice

### Mako Base Unit Specifications

Size	117.3 x 73 x 23.2 mm (4.62 x 2.87 x 0.91 in)
Weight	250 g (8.82 oz)
Interface to Mako Display	Wireless (Bluetooth) or via USB cable
Interface to Probes	USB-C connection
Bluetooth Range	100 m (free-in-air)
Power Source	Rechargeable Li ion battery
Battery Life	20 hours (practical measurement time)
Battery Tested	According to UN 38.3
Memory	Unlimited (via Mako Display)
Operating Temperature	15–35°C
Storage Temperature	-10–50°C





**Mako Probes (R/F, Mammo, Dental)  
General Specifications**

Size	122.5 x 28 x 14.5 mm (4.82 x 1.1 x 0.57 in)
Weight	55 g (1.94 oz)
Detector active areas	Smallest 0.9 x 0.9 mm <sup>2</sup> , Largest 7 x 7 mm <sup>2</sup>
Detector position check	Orientation independent, no check required
Backscatter Protection	Yes

**Mako Ion Chamber Module  
General Specifications**

Size	80 x 27x 16.5 mm (3.15 " x 1.06" x 0.65")
Weight	32 g (1.3 oz)
Compatible probes which can be connected to module:	RTI CT Ion Chamber (10 cm and 30 cm) RTI DAP Chamber (86 x 86 mm and 147 x 147 mm), Ion Chamber Magna 1cc, and other Ion Chambers using Triaxial-to-Lemo adapter

**Broadest angular range**

Unique detector design provides unbeaten angular sensitivity, offering the broadest range of use and best accuracy in practice.

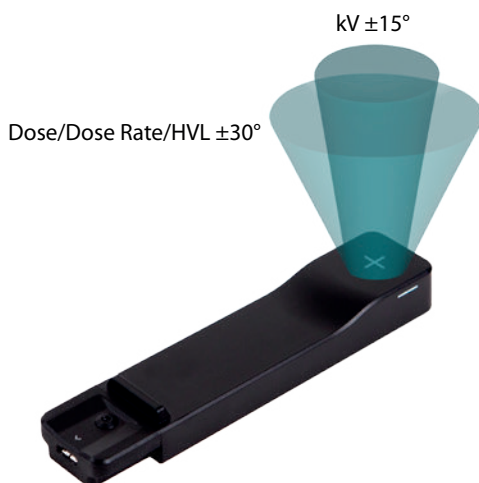

**Mako mAs Module  
General Specifications**

Size	68 x 27 x 14.5 mm (2.68" x 1.06" x 0.57")
Weight	16 g (0.6 oz)
Compatible probes which can be connected to module:	Mako mAs Cable, RTI MAS-2, Mako Test Point Cables

**Mako Legacy Module  
General Specifications**

Size	68 x 27 x 14.5 mm (2.68" x 1.06" x 0.57")
Weight	20 g (0.7 oz)
Compatible probes which can be connected to module:	RTI CT Dose Profiler, RTI Light Probe, RTI Dose Probe, T20, MAS-1, and MAS-2



### Mako R/F Specifications (R/F Probe)

Tube Potential	35 – 155 kV
Min dose rate	2 $\mu$ Gy/s
PPV and kVp	Yes
Uncertainty	$\pm 1.5$ %
Dose	1 nGy – 9999 Gy
Uncertainty	$\pm 5$ % or 5 nGy
Dose Rate	1 nGy/s – 500 mGy/s
Resolution	0.1 nGy/s
Trigg level	25 nGy/s @ exp. time >200 ms 3 $\mu$ Gy/s @ 1 ms 0.3 $\mu$ Gy/s @ 10 ms
Uncertainty	$\pm 5$ % or 1 nGy/s
Time	0.33 ms – 48 h
Resolution	0.33 ms
Bandwidth	Up to 1 kHz
Uncertainty	$\pm 0.5$ % or 0.5 ms
HVL	1 – 15 mm Al
Min dose rate	0.5 $\mu$ Gy/s
Uncertainty	$\pm 5$ % or 0.2 mm Al
Total Filtration	1 – 90 mm Al equivalent
Min dose rate	2 $\mu$ Gy/s
Uncertainty	$\pm 10$ % or 0.2 mm Al
Pulses	1 – 5 000 000
Min peak dose rate	0.25 $\mu$ Gy/s
Min pulse width	0.33 ms
Pulse Rate	0.2 – 260 Hz
Min peak dose rate	0.25 $\mu$ Gy/s
Min pulse width	0.33 ms
Waveforms	0 – 240 s
Resolution	0.33 ms at exposures <15 s
Bandwidth kV	1 kHz
Bandwidth Dose Rate	1 kHz

Specifications are valid at reference conditions derived by RTI (see section "Reference conditions").

The reported expanded uncertainty of measurement is stated as the standard uncertainty of measurement multiplied by the coverage factor  $k = 2$ , which for a normal distribution corresponds to a coverage probability of approximately 95%. The standard uncertainty of measurement has been determined in accordance with EAL Publication EAL-R2.

### Mako Mammography Specifications (Mammo Probe)

Tube Potential	18 – 49 kV
Min dose rate	2 $\mu$ Gy/s
PPV and kVp	Yes
Uncertainty	$\pm 1.5$ % or 0.5 kV
Dose	1 nGy – 9999 Gy
Uncertainty	$\pm 5$ % or 5 nGy
Dose Rate	2 nGy/s – 1 Gy/s
Resolution	0.1 nGy/s
Trigg level	50 nGy/s @ exp. time >200 ms 6 $\mu$ Gy/s @ 1 ms 0.6 $\mu$ Gy/s @ 10 ms
Uncertainty	$\pm 5$ % or 2 nGy/s
Time	0.33 ms – 48 h
Resolution	0.33 ms
Bandwidth	Up to 1 kHz
Uncertainty	$\pm 0.5$ % or 0.5 ms
HVL	0.2 – 4.0 mm Al
Min dose rate	1 $\mu$ Gy/s
Uncertainty	$\pm 5$ % or 0.025 mm Al
Waveforms	0 – 240 s
Resolution	0.33 ms at exposures <15 s
Bandwidth kV	1 kHz
Bandwidth Dose Rate	1 kHz
Supported Radiation Qualities for kV	Every mammography radiation quality also covers use of compression paddle, and use of PMMA and Aluminium phantoms up to 2.5 mm Al equivalent.
W / 0.70 mm Al	0.5 – 0.9 mm Al
W / 50 $\mu$ m Rh	45 – 65 $\mu$ m Rh
W / 50 $\mu$ m Ag	45 – 55 $\mu$ m Ag
W / 75 $\mu$ m Ag	70 – 80 $\mu$ m Ag
W / 0.30 mm Cu	0.25 – 35 mm Cu
W / 1 mm Ti	1 – 1.5 mm Ti
Mo / 30 $\mu$ m Mo	25 – 35 $\mu$ m Mo
Mo / 25 $\mu$ m Rh	20 – 30 $\mu$ m Rh
Mo / 1.0 mm Al	0.8 – 1.2 mm Al
Mo / 0.25 mm Cu	0.25 – 35 mm Cu
Rh / 25 $\mu$ m Rh	20 – 30 $\mu$ m Rh
Rh / 1.0 mm Al	0.8 – 1.2 mm Al
Rh / 30 $\mu$ m Ag	25 – 35 $\mu$ m Ag
Rh / 0.25 mm Cu	0.25 – 35 mm Cu

Specifications are valid at reference conditions derived by RTI (see section "Reference conditions").

The reported expanded uncertainty of measurement is stated as the standard uncertainty of measurement multiplied by the coverage factor  $k = 2$ , which for a normal distribution corresponds to a coverage probability of approximately 95%. The standard uncertainty of measurement has been determined in accordance with EAL Publication EAL-R2.



### Mako Dental Specifications (Dental Probe)

Tube Potential	35 – 125 kV
Min dose rate	2 $\mu$ Gy/s
PPV and kVp	Yes
Uncertainty	$\pm 1.5\%$
Dose	1 nGy – 9999 Gy
Uncertainty	$\pm 5\%$ or 5 nGy
Dose Rate	1 nGy/s – 500 mGy/s
Resolution	0.1 nGy/s
Trigg level	25 nGy/s @ exp. time >200 ms 3 $\mu$ Gy/s @ 1 ms 0.3 $\mu$ Gy/s @ 10 ms
Uncertainty	$\pm 5\%$ or 1 nGy/s
Time	0.33 ms – 48 h
Resolution	0.33 ms
Bandwidth	Up to 1 kHz
Uncertainty	$\pm 0.5\%$ or 0.5 ms
HVL	1 – 15 mm Al
Min dose rate	0.5 $\mu$ Gy/s
Uncertainty	$\pm 5\%$ or 0.2 mm Al
Total Filtration	1 – 25 mm Al equivalent
Min dose rate	2 $\mu$ Gy/s
Uncertainty	$\pm 10\%$ or 0.2 mm Al
Pulses	1 – 5 000 000
Min peak dose rate	0.25 $\mu$ Gy/s
Min pulse width	0.33 ms
Pulse Rate	0.2 – 260 Hz
Min peak dose rate	0.25 $\mu$ Gy/s
Min pulse width	0.33 ms
Waveforms	0 – 240 s
Resolution	0.33 ms at exposures <15 s
Bandwidth kV	1 kHz
Bandwidth Dose Rate	1 kHz

Specifications are valid at reference conditions derived by RTI (see section "Reference conditions").

The reported expanded uncertainty of measurement is stated as the standard uncertainty of measurement multiplied by the coverage factor  $k = 2$ , which for a normal distribution corresponds to a coverage probability of approximately 95%. The standard uncertainty of measurement has been determined in accordance with EAL Publication EAL-R2.

### Invasive mA and mAs specifications (Mako mAs Module with Mako mAs Cable)

mAs	0.001–9999 mAs
Resolution	0.001 mAs
Uncertainty	$\pm 1\%$ or 0.001 mAs
mA	0.1 – 2000 mA
Resolution	0.01 mA
Uncertainty	$\pm 1\%$ or 0.01 mA
Time	0.5 ms – 48 h
Resolution	0.5 ms
Bandwidth	0.7 kHz
Uncertainty	$\pm 0.5\%$ or 0.5 ms
Pulses	1 – 5 000 000
Min pulse width	0.5 ms
Uncertainty	$\pm 0.5$ pulses
Pulse Rate	0.2 – 260 Hz
Min pulse width	0.5 ms
Uncertainty	$\pm 0.5$ pulses/s
mAs/Pulse	0.001 – 9999
Resolution	0.001 mAs
Uncertainty	$\pm 1\%$
Waveforms	0 – 120 s
Resolution	0.5 ms at exposures <15 s
Bandwidth	0.7 kHz
Mako mAs Cable:	3m length



### Non-invasive mA and mAs specifications (Mako mAs Module with MAS-2)

mAs	0.1-9999 mAs
Resolution	0.1 mAs
Uncertainty	±5%
mA	10 - 4000 mA
Resolution	1 mA
Uncertainty	±5% or 2 mA
Time	0.5 ms - 48 h
Resolution	0.5 ms
Bandwidth	0.7 kHz
Uncertainty	±0.5% or 0.5 ms
Pulses	1 - 5 000 000
Min pulse width	0.5 ms
Uncertainty	±0.5 pulses
Pulse Rate	0.2 - 260 Hz
Min pulse width	0.5 ms
Uncertainty	±0.5 pulses/s
mAs/Pulse	0.1 - 9999
Resolution	1 mAs
Uncertainty	±5%
Waveforms	0 - 120 s
Resolution	0.5 ms at exposures <15 s
Bandwidth	0.7 kHz

### RTI CT Ion Chamber 10 & 30 cm Specifications (with Mako Ion Chamber Module)

Connector type	LEMO triaxial
Cable	2 m, low noise triaxial
Active volume	5.3 cm <sup>3</sup> (16 cm <sup>3</sup> )
Effective length	100 mm (300 mm)
Diameter	12 mm, 12.6 incl O-rings
Typical leakage	±20 fA
Radiation quality	70 - 150 kV
Sensitivity	30 mGycm/nC
Energy dependence	±1%
Dose Length Product	0.01 mGycm/nC
Uncertainty	±5 % or 0.01 mGycm
Rate	0.3 mGycm/s - 3 Gycm/s
Resolution	0.01 mGycm/s
Uncertainty	±5 % or 0.03 mGycm/s
Time	3.3 ms - 48 h
Resolution	3.3 ms
Bandwidth	100 Hz
Uncertainty	±0.5 % or 3.3 ms
Waveforms	0-120 ms
Resolution	3.3 ms at exposure <15 s
Bandwidth	100 Hz
Bandwidth Dose Rate	100 Hz

Notice: Information within brackets ( ) are valid for the 30 cm chamber.



### RTI DAP Chamber Specifications 86x86 & 147x147 mm (with Mako Ion Chamber Module)

Cable length	2.0 m (6.6 ft)
Dose rate range	6 mGycm <sup>2</sup> /s - 1800 mGycm <sup>2</sup>
Dose range	0.6 mGycm <sup>2</sup> - 1 kGycm <sup>2</sup>
Inaccuracy	±6 % at reference conditions RQR5, ±10 % RQR2 to RQR10
Exposure time	> 100 ms
Quality equivalent filtration (70 kV)	0.2 mm Al

Notice: Information within brackets ( ) are valid for the 30 cm chamber.

Dose Length Product Uncertainty	0.01 mGycm - 9999 mGycm ±5 % or 0.01 mGycm
Rate Resolution Uncertainty	0.3 mGycm/s - 3 Gycm/s 0.01 mGycm/s ±5 % or 0.03 mGycm/s
Time Resolution Bandwidth Uncertainty	3.3 ms - 48 h 3.3 ms 100 Hz ±0.5 % or 3.3 ms
Waveforms Resolution Bandwidth	0-120 ms 3.3 ms at exposure <15 s 100 Hz



### Ion Chamber Magna 1cc Specifications (with Mako Ion Chamber Module)

Active volume	1 cm <sup>3</sup>
Height	25.4 mm
Diameter	41.3 mm
Inner plate separation	8 mm
Weight	200 g
Cable length	2 m
Materials	Air equivalent plastic, acrylic
Entrance window	Kapton conductive film
Typical leakage	±5 fA
Radiation quality	20 - 150 kV
Energy dependence	±2 %
Typical sensitivity	20 mGy/nC
Dose Range	0.002 mGy - 1 kGy
Dose Rate Range Uncertainty	0.02 mGy/s - 2 Gy/s ±5 % or 0.02 mGy/s
Time Resolution Bandwidth Uncertainty	3.3 ms - 48 h 3.3 ms 100 Hz ±0.5 % or 3.3 ms
Waveforms Resolution Bandwidth	0-120 ms 3.3 ms at exposure <15 s 100 Hz



### RTI Light Probe Specifications (with Mako Legacy Module)

Spectral Response	CIE V( $\lambda$ ) (Photopic)
Field of view	
Lux adapter	180° (Cosine)
Monitor adapter	Ø 7 mm
Luminance	0.04 cd/m <sup>2</sup> - 128 kcd/m <sup>2</sup> ±5% or ±0.008 cd/m <sup>2</sup>
Illuminance	0.014 lx - 48 klx ±5% or 0.003 lx

### RTI CT Dose Profiler Specifications (with Mako Legacy Module)

General specifications	
Length	210 mm
Diameter	12.5 mm
Weight	50 g
Sensor width	250 $\mu$ m
Cable length	4.0 m (13.1 ft)
Dose	
Range	0.05 $\mu$ Gy - 9999 Gy
Uncertainty	±5 %
Dose Rate	
Range	0.5 $\mu$ Gy/s - 3 Gy/s
Uncertainty	±5 % or 0.1 $\mu$ Gy/s





### RTI Dose Probe Specifications (with Mako Legacy Module)

#### General specifications

Dimensions	20 x 45 x 7.4 mm (0.79" x 1.8" x 0.29")
Weight	85 g (3 oz)
Cable length	2.0 m (6.6 ft)
Backscatter protected	Yes
Dose:	100 pGy – 1.5 kGy. 12 nR – 170 kR (± 5%)
Dose rate:	4 nGy/s – 150 mGy/s (± 5 % or ±10 nGy/s) 0.46 µR/s – 16 R/s (±5 % or ±1 µR/s)
Time:	0.1 ms – 34000 s (±1 % or ±0.5 ms)
Pulses:	1 – 65535 pulses (±1 pulse)
Dose per pulse:	1 nGy/pulse – 0.3 Gy/pulse
Pulse rate/frequency:	0.5 – 100 Hz
Pulse width:	4 ms - 2000 s



### RTI T20 Specifications (with Mako Legacy Module)

#### General specifications

Dimensions	35 × 320 × 6.0 mm (metal 23,5 × 5,6 mm)
Weight approx.	75 g (2.6 oz)
Cable length	2.0 m (6.6 ft)
Operating temp. and humidity relative humidity	-10 °C to +50 °C at <85 %
Temperature and air pressure	Insensitive, no TP correction is necessary
Backscatter protection	Yes
Angular dependence	Very close to ideal Cosine (flat sensor)
Dose	700 pGy – 10 kGy (80 nR – 11 MR)
Dose rate	27 nGy/s – 500 mGy/s (3 µR/s – 57 R/s)
Inaccuracy	< 3 %
Time	0.33 ms – 9999 s
Pulses	3 – 9999 pulses
Pulse rate/frequency	1/6 - 260 Hz
Typical energy dependence	+1,6 to -0,4 % (radiation quality R1) +1,9 to -1,5 % (radiation quality RQR)



### MakoHolder and Stand

The Mako Holder and Stand has one Stand framework with three different Holder configurations.

**Holder A** is compatible with the Mako R/F Probe, the Mako Mammo Probe and the Mako Dental Probe.

**Holder B** is compatible with the RTI Dose Probe and RTI CT Ion Chamber (10cm & 30cm).

**Holder C** is compatible with HVL filters provided with the Mako kits (dimensions 33x33 mm).

The base of the Stand can also hold the Mako R/F, Mammo & Dental Probes.

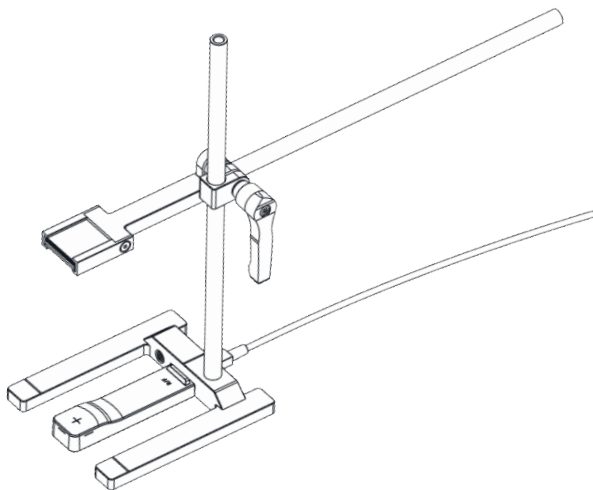

### Mako Panoramic Dental Holder

The Mako Panoramic Dental Holder is designed to hold the Mako Dental Probe in position during panoramic dental measurements.

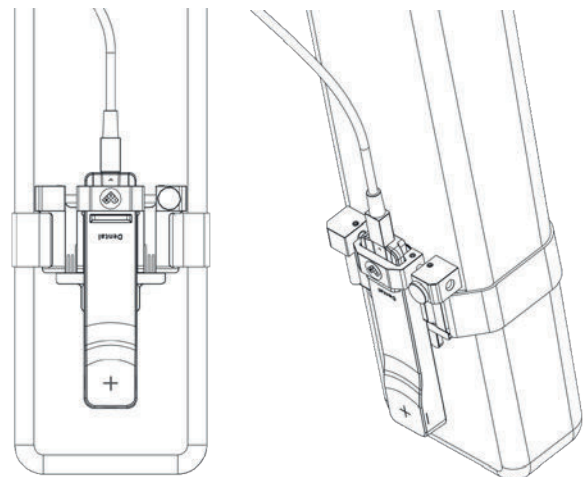

**Dimensions. All units in mm**

**Mako Base Unit**

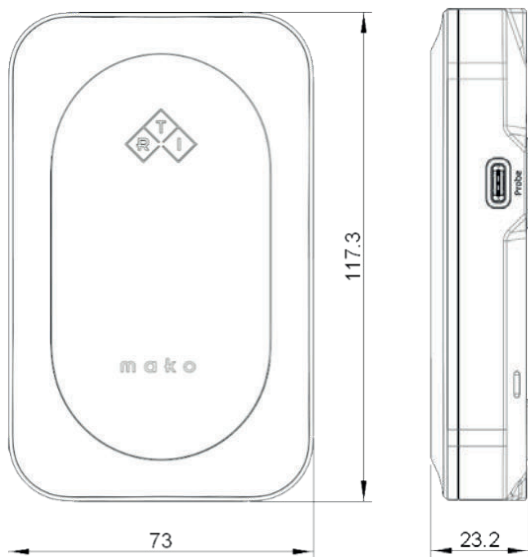

**Mako Ion Chamber Module**

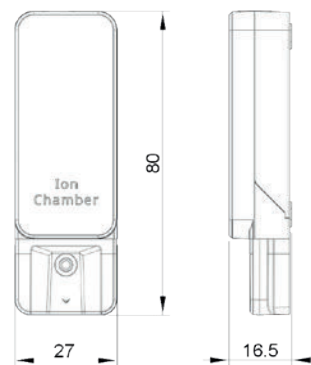

**Mako mAs Module**

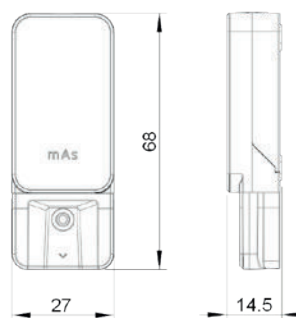

**Mako Probes**

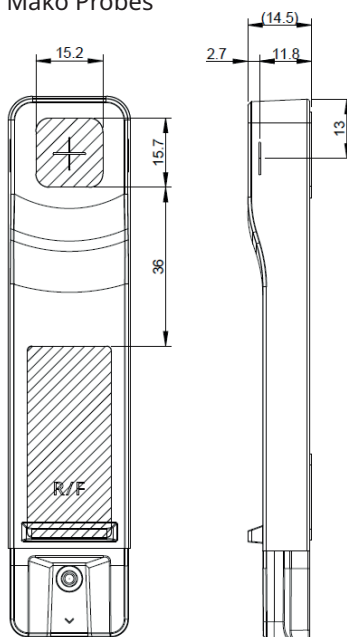

**Mako Legacy Module**

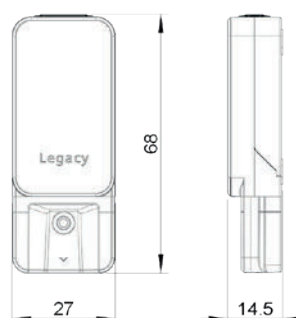

**Reference conditions**

Specifications in this document are valid at reference conditions derived by RTI for a typical X-ray tube and HF/DC generator. Unless otherwise stated, reference conditions are at SDD 100 cm, 100 mA and 100 ms. For R/F and dental specifications, X-ray tube with tungsten (W) target, 12° anode angle, and a total filtration of 3 mm Al equivalent. For mammography specifications, X-ray tube with tungsten (W) target, 16° anode angle, and a total filtration of 0.7 mm Al. For a parameter that is a part of the reference condition, only that parameter is changed when this specific parameter is expressed in specifications.

The reported expanded uncertainty of measurement is stated as the standard uncertainty of measurement multiplied by the coverage factor  $k = 2$ , which for a normal distribution corresponds to a coverage probability of approximately 95%. The standard uncertainty of measurement has been determined in accordance with EAL Publication EAL-R2.

# c/o RTI

What we do matters. To patients. To professionals. To us.

It is more than algorithms, technology and design.

It is about setting the standard for quality assurance  
of X-ray imaging.



INDEPENDENT X-RAY  
QUALITY ASSURANCE